

Precision Chamfering

Nobur® JB Automatic Back-Chamfering Tool

For back-chamfering or deburring on drill presses, CNC machines, tool or turret lathes, multi-spindle machines and jig boring machines.



- Consistently accurate back-chamfering, deburring, and back-countersinking operations
- Pilots in hole for precise concentricity
- Rigid support of the cutter virtually eliminates deflection
- Micrometer-stop adjustment
- Standard pilots and cutters for hole sizes from 3/16 to 3/4" (4.75 to 19.05mm)
- Special pilots and cutters available upon request

Operating Principle

Nobur® JB Series
AUTOMATIC
BACK-CHAMFERING

Illustrated below is the basic operating principle for the **Nobur® JB** Automatic Back-Chamfering tool.

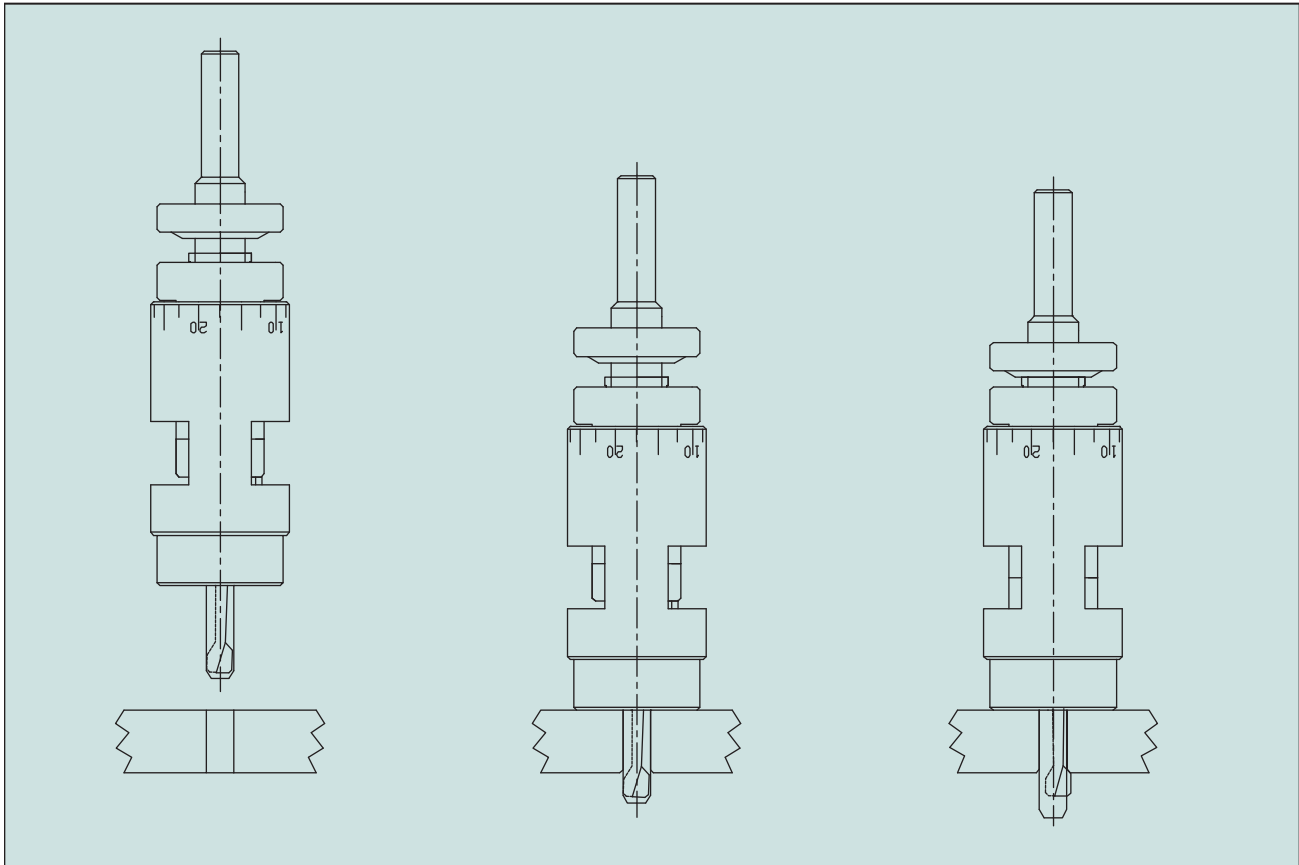

1 Approach Stroke

The **Nobur® JB** tool is rotating in a machine spindle. The spindle is lowered to bring the tool into position to enter the bore.

2 Feed Stroke

The pilot locates in the bore, stopping against the face of the workpiece. As the spindle continues to travel, the tool is compressed so that the cutter feeds out radially into the work. The cutter is rigidly supported in the bore by the pilot to eliminate deflection and ensure concentricity.

3 End of Feed Stroke

Radial depth of cut is obtained when the micrometer-stop nut bottoms out. Chamfer location is controlled by rotation of the stop collar, which moves the stop collar extension up or down to position the cutter for accurate chamfer location.

Specifications

Nobur® JB Series
AUTOMATIC
BACK-CHAMFERING

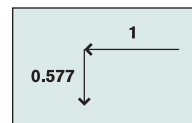
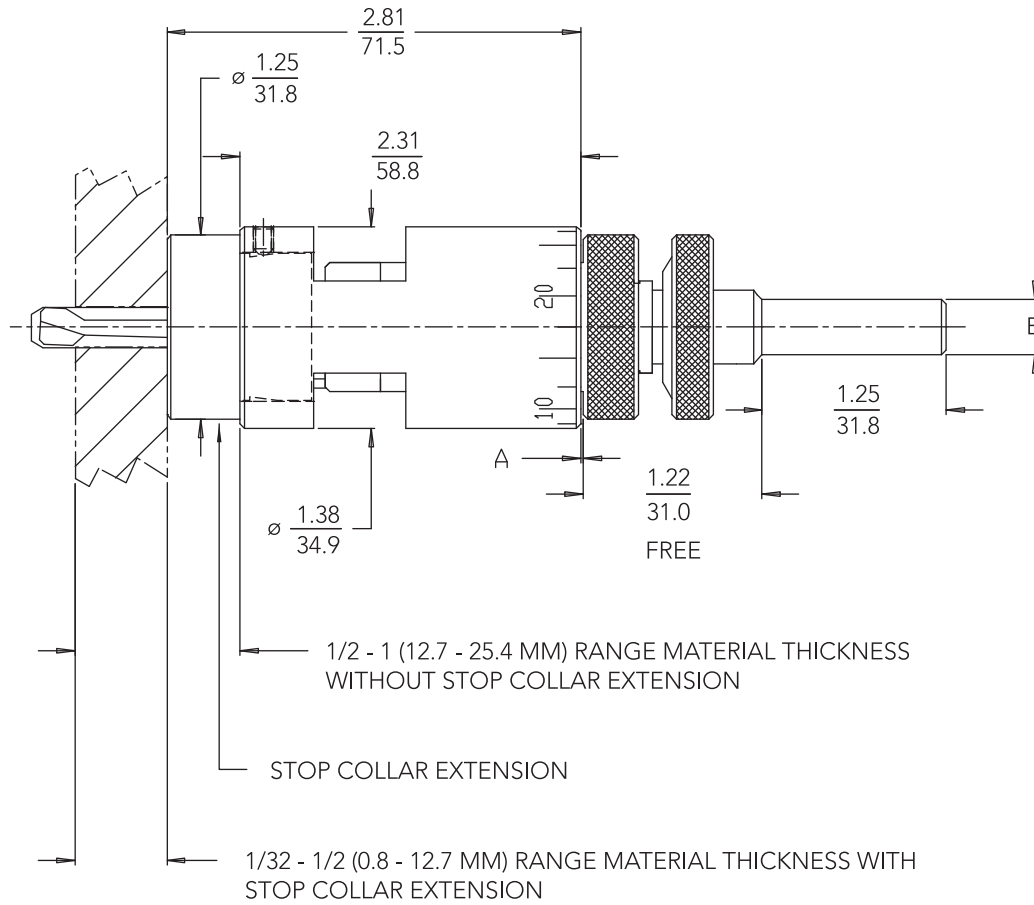

The **Feed Ratio** is the ratio of vertical to horizontal movement. The **Maximum Feed Stroke** is 0.38 in. (9.4mm)

INCH [METRIC]

CAPACITY *		(A) MAX.		(B) SHANKS **
IN	MM	IN	MM	STRAIGHT SHANKS
0.88	22.4	0.78	19.8	1/4 3/8 w/tang

* Capacity means the suggested maximum chamfer diameter. Dependent upon cutting forces and bore diameter. Stated capacity is for steel.

** Shank is included with head. Shanks other than shown can be supplied upon request.

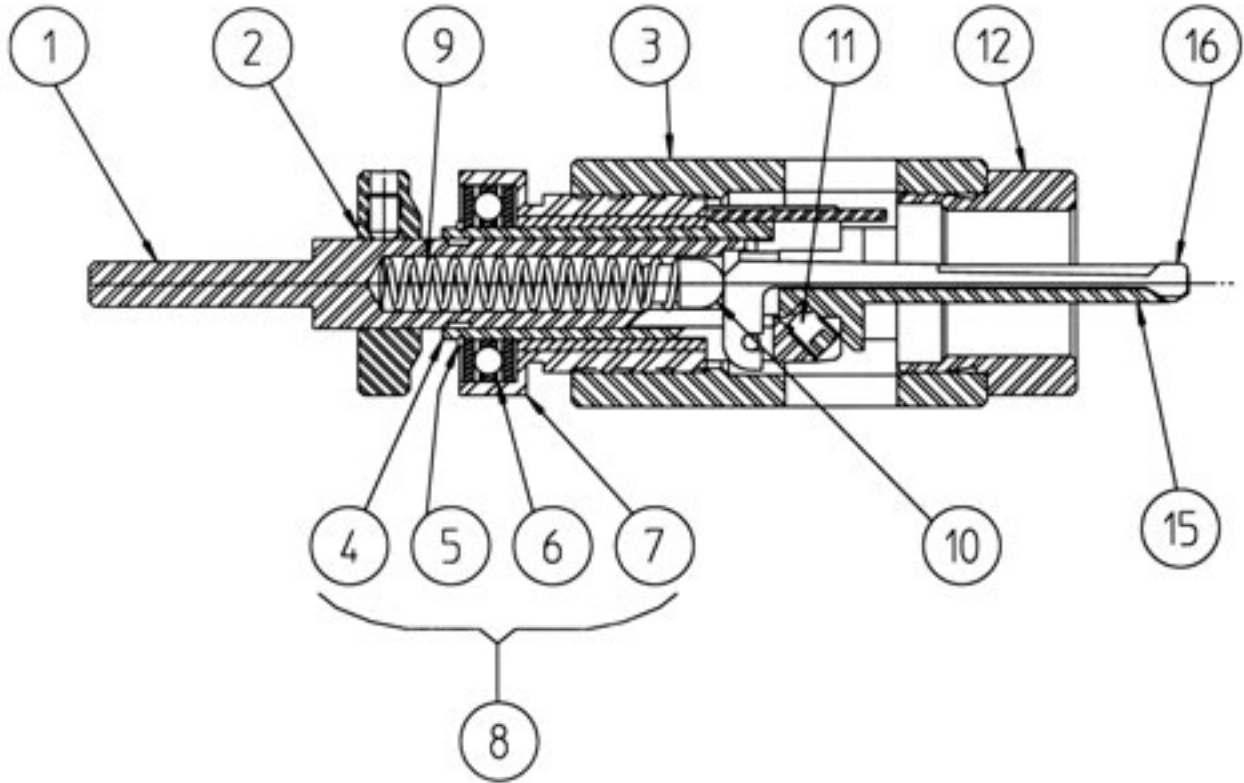

1 Body Holder	5 Retaining Ring	9 Compression Spring	15 Pilot
2 Stop Nut	6 Ball Thrust Bearing	10 Ball (19/64) diameter	16 Blade
3 Stop Collar	7 Bearing Cage	11 Pilot Retaining Screw	
4 Keyed Transport Sleeve	8 Transport Assembly	12 Stop Collar Extension	

Nobur[®] JB Tool

back-chamfers both sides of holes in large single-speed gear ring

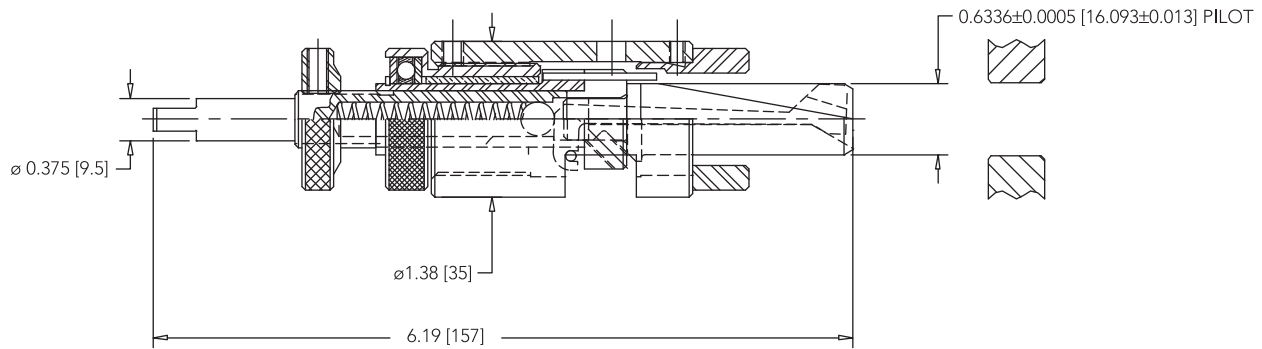

Nobur[®] JB Tool

deburrs back side of yoke

