

Operating Principle

AR Series
AUTOMATIC RECESSING

The **AR** Series Automatic Recessing Tool is made up of three basic components: head, cutter, and pilot. The head is usually standard and consists of shank and tool body. All cutters and pilots are manufactured to suit your application.

AR16 Recessing Head

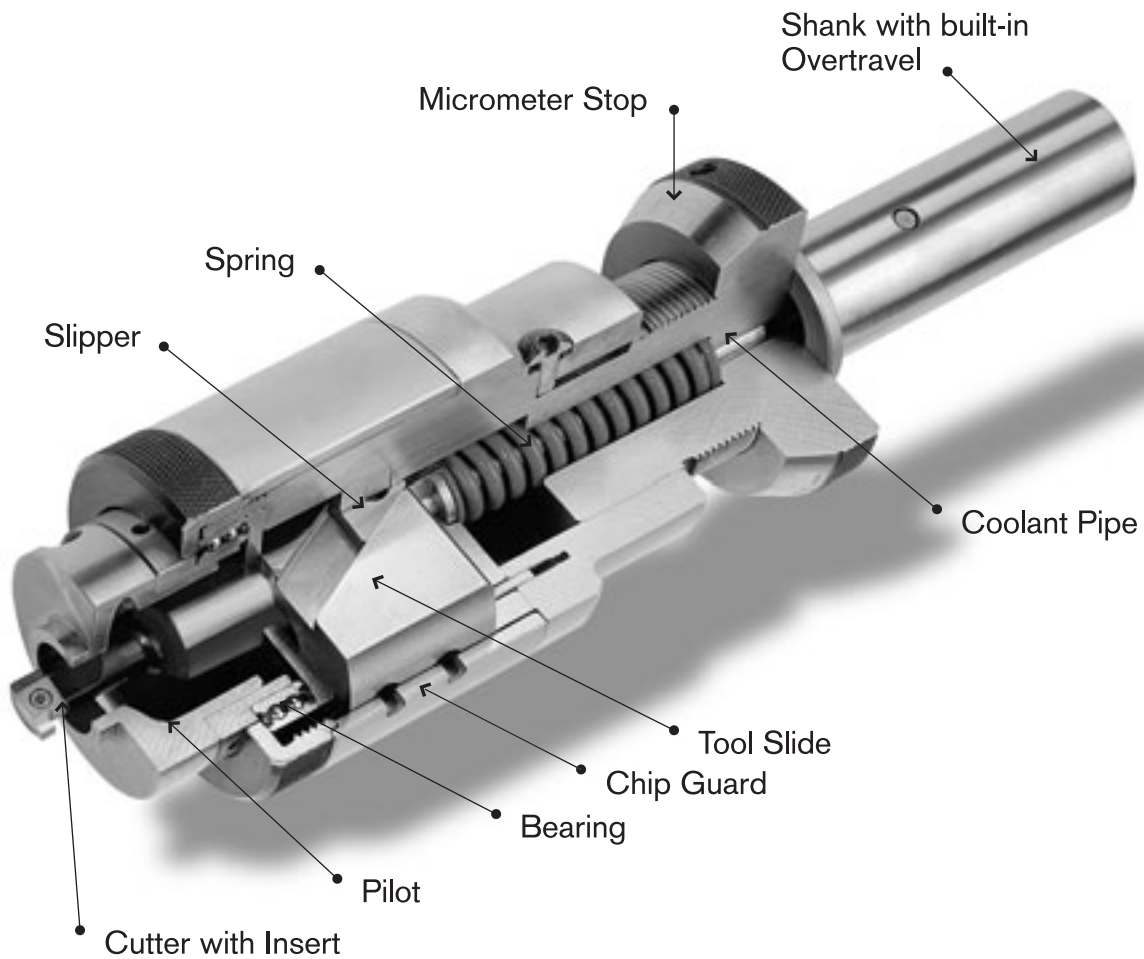

Operating Principle

AR Series
AUTOMATIC RECESSING

Illustrated below is the basic operating principle for **AR**, **ARSP** and **ARX** Recessing Heads. The head type shown below is the **AR** model.

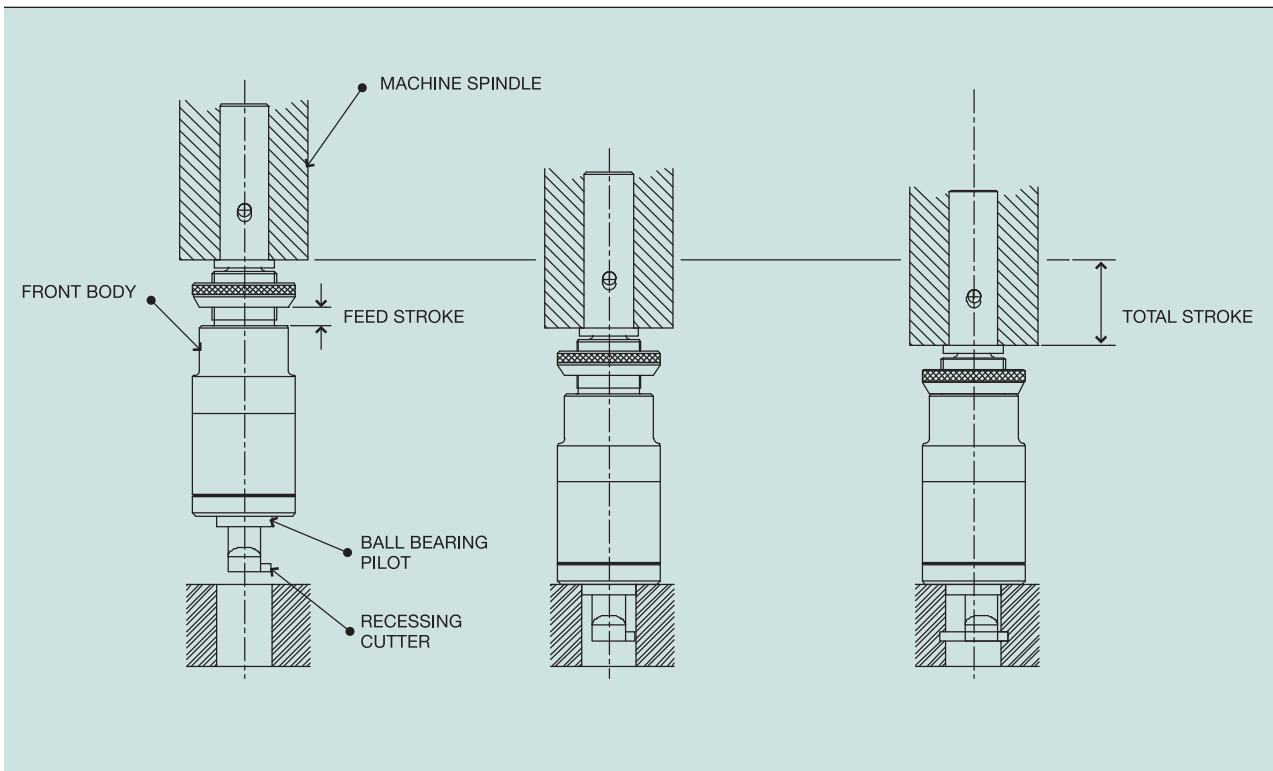

1 Approach Stroke

The tool is rotating in a machine spindle. The spindle is lowered, and the tool moves into position.

2 Feed Stroke

The pilot is located in the bore against the face of the workpiece. Downward pressure causes compression of the recessing head, thereby actuating the slide mechanism which feeds the cutter out radially into the work.

3 End of Feed Stroke

The correct depth of cut is obtained when the micrometer stop bottoms against the front body, making it impossible to continue the cut. Groove location is controlled by the tool adjustment system on the shank end of the cutter.

When the spindle is retracted, pressure is relieved, and the tool is withdrawn from the bore. The cutter retracts and returns to its starting position. The piloted bearing absorbs both thrust and rotation. It remains stationary in the bore of the workpiece, under load, until the cutter is fully retracted, thereby preventing scoring of the workpiece.

AR Recessing Head



General purpose tool for use on:

AR16

- Drill presses
- Jig boring machines
- Milling machines
- CNC machines
- Tool lathes
- Turret lathes
- Horizontal boring machines
- Screw machines
- Special purpose machines

Features:

- Pilots off workpiece or jig plate
- Micrometer stop controls depth of cut
- Tool adjustment controls axial location
- Through-shank coolant is standard
- Overtravel shanks are standard

AR Recessing Head

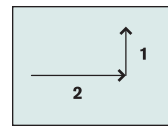
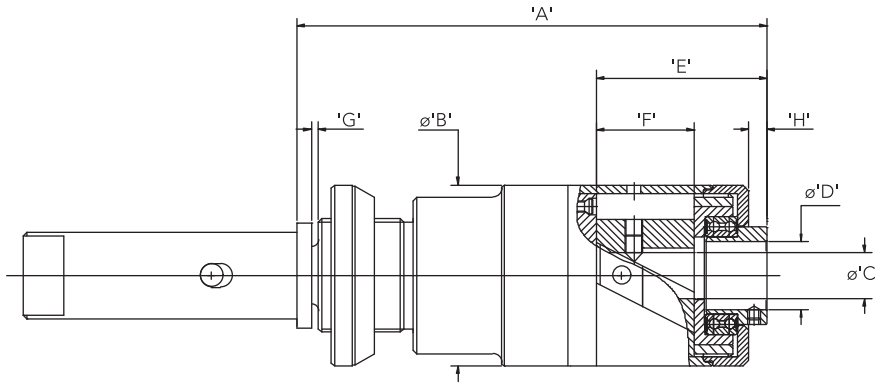

The **Feed Ratio** is the ratio of spindle to radial cutter movement

INCH [METRIC]

HEAD TYPE	APPROX. CAPACITY RANGE ★	MAXIMUM CUTTER TRAVEL	SHANKS	(A) FREE LENGTH	(B) TOOL BODY	(C) CUTTER SHANK	(D) MASTER PILOT	(E) REF MIN CUTTER LENGTH	(F) BORE DEPTH	(G) OVERTRAVEL	(H) REF TO FRONT NUT
AR10	0.216 [5.5] 0.984 [25.0]	0.197 [5.0]	0.750in/20mm	4.083 [103.70]	ø1.58 [ø40.0]	ø0.394 [ø10.0]	ø0.591 [ø15.0]	1.48 [37.6]	0.85 [21.60]	0.06 [1.5]	0.157 [4.0]
			No 2 MT	4.894 [124.32]							
			SK40/CAT40	6.248 [158.70]							
			BT40	5.657 [143.70]							
AR16	0.590 [15.0] 1.772 [45.0]	0.276 [7.0]	1.000in/25mm	5.547 [140.90]	ø2.56 [ø65.0]	ø0.630 [ø16.0]	ø1.416 [ø36.0]	2.03 [51.5]	1.19 [30.23]	0.06 [1.5]	0.187 [4.76]
			No 3 MT	5.796 [147.23]							
			SK40/CAT40	7.713 [195.90]							
			SK50/CAT50	6.299 [160.00]							
			BT40	7.122 [180.90]							
			BT50	8.152 [178.90]							
AR20	0.866 [22.0] 2.362 [60.0]	0.394 [10.0]	1.500in/40mm	6.591 [167.40]	ø3.15 [ø80.0]	ø0.787 [ø20.0]	ø1.772 [ø45.0]	2.43 [61.8]	1.46 [37.08]	0.12 [3.0]	0.224 [5.70]
			SK40/CAT40	8.756 [222.40]							
			SK50/CAT50	7.343 [186.50]							
			BT40	8.165 [207.40]							
			BT50	8.087 [205.40]							

★ The capacity range shown is **not** intended as an absolute limitation. The maximum diameter shown in the chart is defined as the suggested maximum groove diameter, dependent upon cutting forces, and intended for the sake of comparison only.

AR Recessing Head

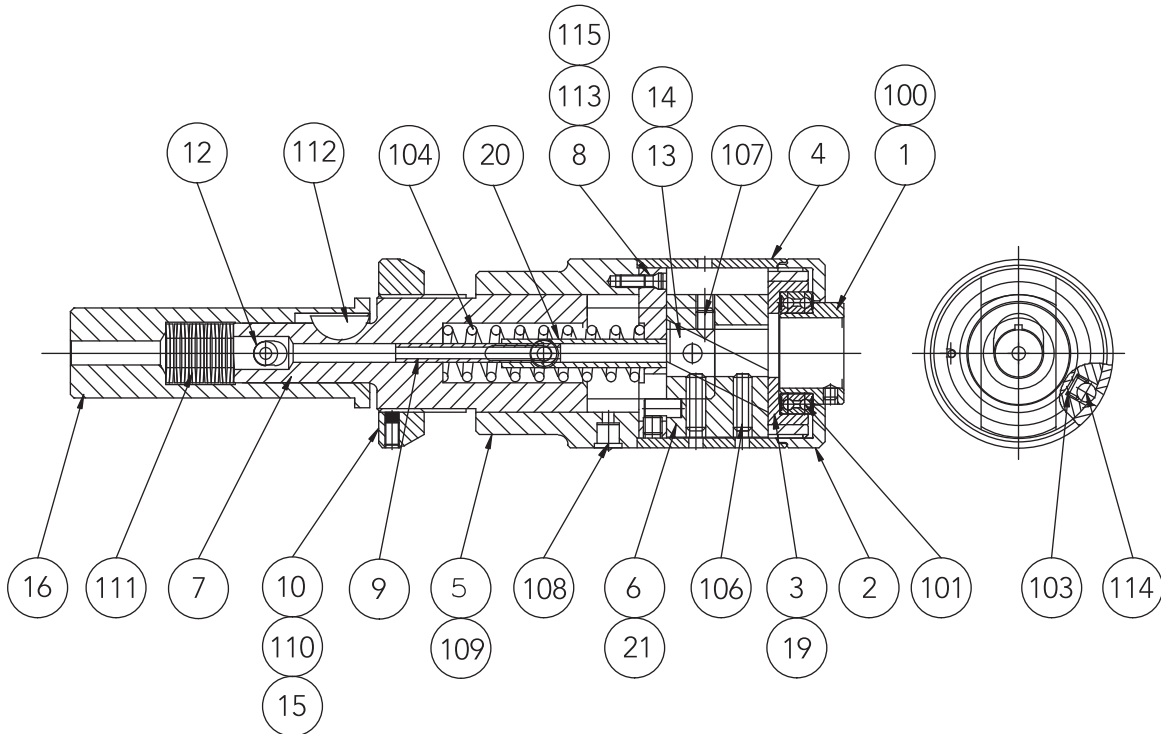

1 Master Pilot	9 Coolant Pipe	20 Spring Plate Pipe	108 Oiler
2 Front Nut	10 Micrometer Nut	21 Centralising Pin	109 Retaining Screw
3 Back Plate	12 Over-rider Dowel	100 Set Screw	110 Micrometer Screw
4 Chip Guard	13 Slipper	101 Double Angular Contact Bearing	111 Disc Springs
5 Front Body	14 Slipper Pin	103 Spring	112 Key
6 Toolslide	15 Copper Pad	104 Spring	113 Torx Screw
7 Rear Body	16 Shank	106 Tool Clamp Screw	114 Ball Bearing
8 Spring Plate	19 Back Plate Dowel	107 Tool Adjust Screw	115 Centralising Screw

ARSP Short-Pilot Head

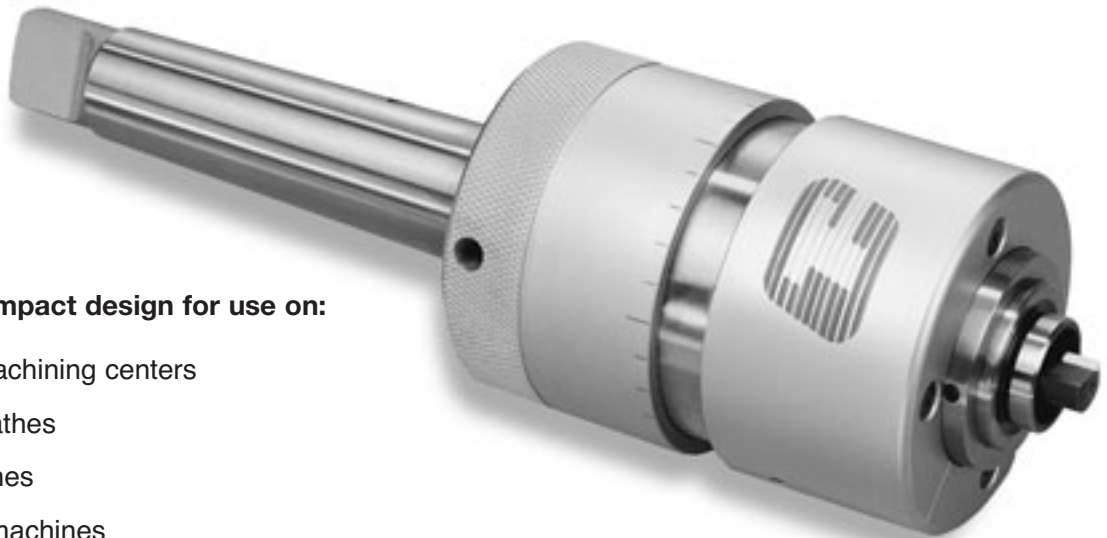

Short, compact design for use on:

- CNC machining centers
- Turret lathes
- Tool lathes
- Screw machines
- Special purpose machines

Features:

- For applications with work length restrictions
- Minimal overall length
- Pilots off workpiece
- Micrometer stop controls depth of cut
- Tool adjustment controls axial location
- Through-tool coolant
- Overtravel shanks are standard

ARSP Short-Pilot Head

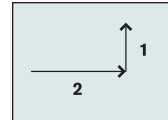
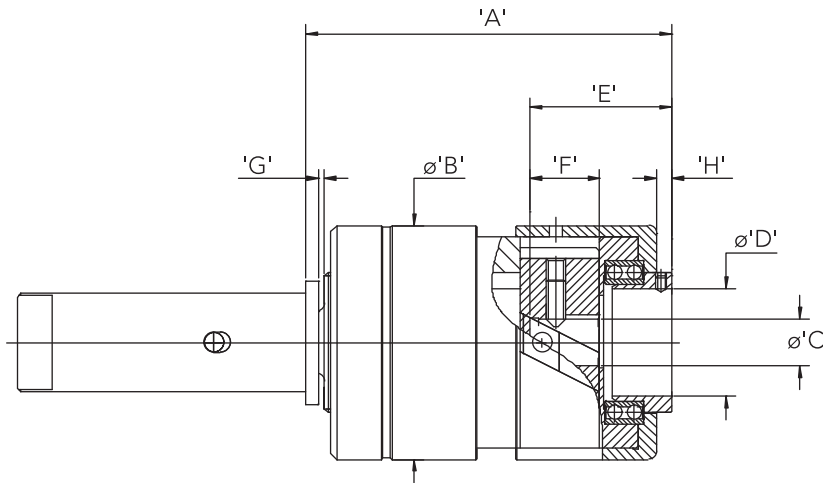

The **Feed Ratio** is the ratio of spindle to radial cutter movement

INCH [METRIC]

HEAD TYPE	APPROX. CAPACITY RANGE *	MAXIMUM CUTTER TRAVEL	SHANKS	(A) FREE LENGTH	(B) TOOL BODY	(C) CUTTER SHANK	(D) MASTER PILOT	(E) REF MIN CUTTER LENGTH	(F) BORE DEPTH	(G) OVERTRAVEL	(H) REF TO FRONT NUT
ARSP1	0.216 [5.5]	0.118 [3.0]	0.750in/20mm	2.510 [63.75]	ø1.70 [ø43.25]	ø0.394 [ø10.0]	ø0.591 [ø15.0]	1.09 [27.6]	0.63 [16.0]	0.06 [1.5]	0.160 [4.05]
	0.984 [25.0]		No 2 MT	3.322 [84.37]							
ARSP2	0.590 [15.0]	0.197 [5.0]	1.000in/25mm	3.699 [93.95]	ø2.36 [ø60.0]	ø0.472 [ø12.0]	ø1.091 [ø27.7]	1.44 [36.5]	0.81 [20.5]	0.06 [1.5]	0.158 [4.00]
	1.772 [45.0]		No 3 MT	3.948 [100.28]							

* The capacity range shown is **not** intended as an absolute limitation. The maximum diameter shown in the chart is defined as the suggested maximum groove diameter, dependent upon cutting forces, and intended for the sake of comparison only.

ARSP Short-Pilot Head

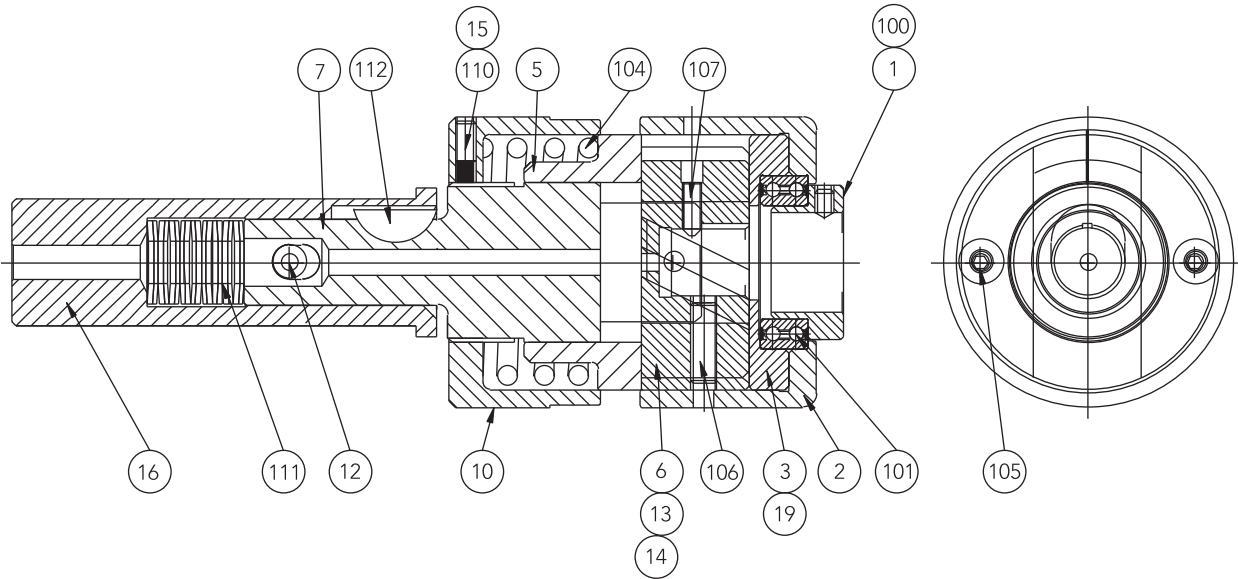

1 Master Pilot	10 Micrometer Nut	19 Back Plate Dowel	107 Tool Adjust Screw
2 Front Shell	12 Over-rider Dowel	100 Set Screw	110 Micrometer Screw
3 Back Plate	13 Slipper	101 Double Angular Contact Bearing	111 Disc Springs
5 Front Body	14 Slipper Pin	104 Spring	112 Key
6 Toolslide	15 Copper Pad	105 Head Screw	
7 Rear Body	16 Shank	106 Tool Clamp Screw	

ARX External Head



External grooving tool for use on:

- Drill presses
- Milling machines
- CNC machines
- Turret lathes
- Screw machines
- Special purpose machines

Features:

- Pilots off workpiece
- Micrometer stop controls depth of cut
- Tool adjustment is controlled within the fitted tooling
- Overtravel shanks are standard
- Optional balance block available with two-slot chip guard for high-speed applications

ARX Tooling Components

AR Series
AUTOMATIC RECESSING

ARX toolholder, cartridge, and insert are shown below.
Replaceable carbide inserts are used where applications permit.

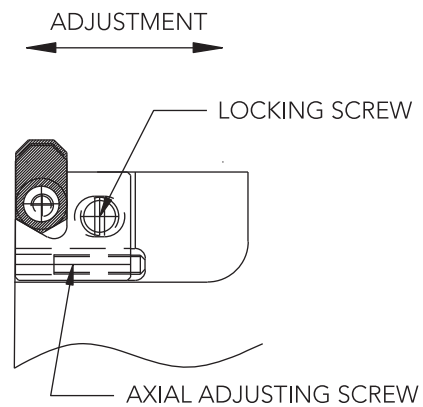
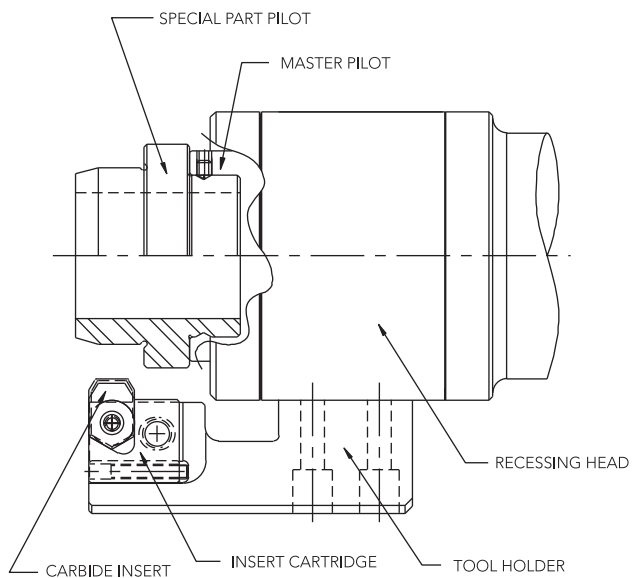
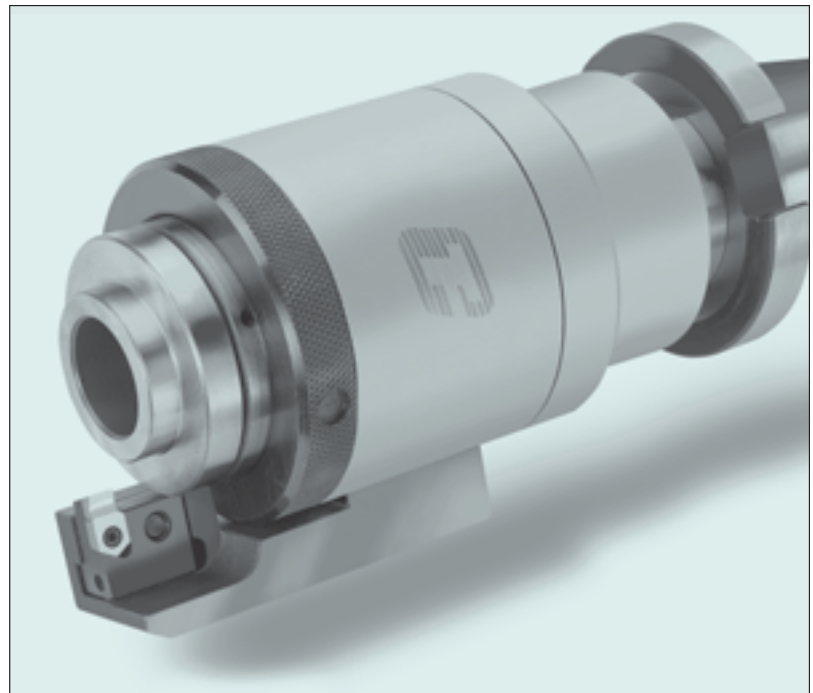

Drawing depicts adjustment of groove location, as measured from the end of the part.

ARX toolholders, insert cartridges, and carbide inserts are made to order from standard blanks. Part pilots are designed and manufactured to suit the application; the master pilot is part of the recessing head.

ARX External Head

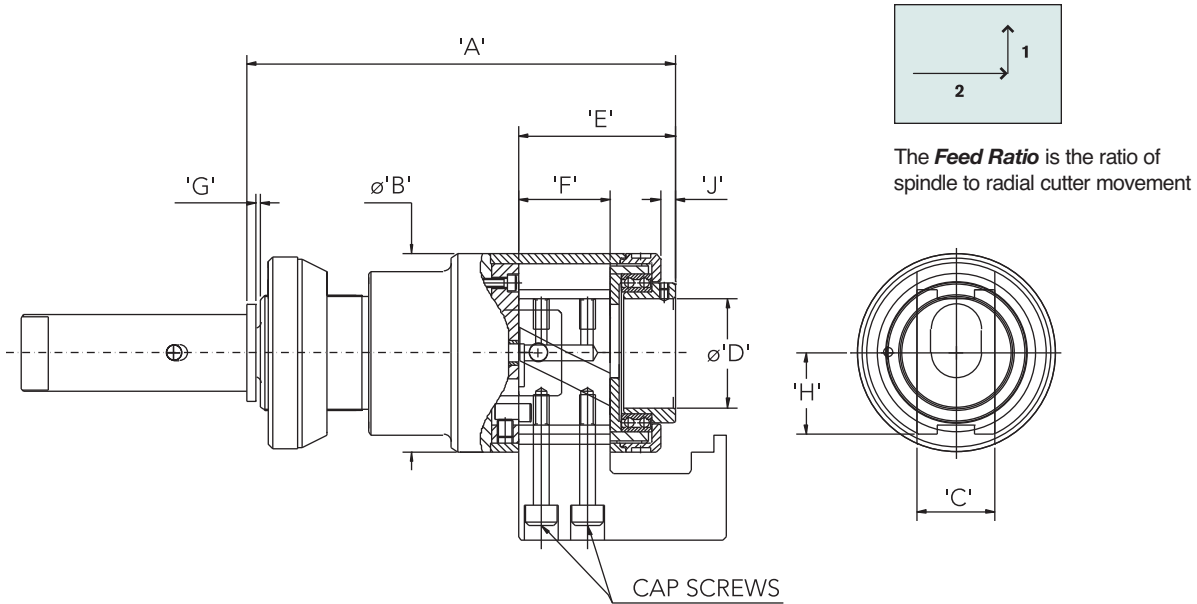

INCH [METRIC]

HEAD TYPE	CAPACITY RANGE *		MAXIMUM CUTTER TRAVEL	SHANKS	(A) FREE LENGTH	(B) TOOL BODY	(C) CUTTER SHANK	(D) MASTER PILOT	(E) REF MIN CUTTER LENGTH	(F) BORE DEPTH	(G) OVER TRAVEL	(H) MOUNTING	(J) REF TO FRONT NUT
	PART DIAMETER	GROOVE LOCATION											
ARX10	0.157–0.787 [4.0–20.0]	UP TO 1.250 [31.75]	0.197 [5.0]	0.750in/20mm	4.083 [103.70]	ø1.58 [ø40.0]	0.625 [15.88]	ø0.591 [ø15.0]	1.48 [37.6]	0.85 [21.60]	0.06 [1.5]	0.636 [16.16]	0.157 [4.0]
				No 2 MT	4.894 [124.32]								
				SK40/CAT40	6.248 [158.70]								
				BT40	5.657 [143.70]								
ARX16	0.630–1.654 [16.0–42.0]	UP TO 1.375 [34.93]	0.276 [7.0]	1.000in/25mm	5.547 [140.90]	ø2.56 [ø65.0]	1.000 [25.40]	ø1.416 [ø36.0]	2.03 [51.5]	1.19 [30.23]	0.06 [1.5]	1.048 [26.63]	0.187 [4.76]
				No 3 MT	5.796 [147.23]								
				SK40/CAT40	7.713 [195.90]								
				SK50/CAT50	6.299 [160.00]								
				BT40	7.122 [180.90]								
BT50	8.152 [178.90]												
ARX20	0.866–2.992 [22.0–76.0]	UP TO 1.500 [38.10]	0.394 [10.0]	1.500in/40mm	6.591 [167.40]	ø3.15 [ø80.0]	1.250 [31.75]	ø1.772 [ø45.0]	2.43 [61.8]	1.46 [37.08]	0.12 [3.0]	1.294 [32.87]	0.224 [5.70]
				SK40/CAT40	8.756 [222.40]								
				SK50/CAT50	7.343 [186.50]								
				BT40	8.165 [207.40]								
				BT50	8.087 [205.40]								

* The capacity range shown is **not** intended as an absolute limitation. It defines the normal range when using standard components. The diameter range represents the approximate part diameter. The groove location is the approximate distance to the groove measured from the end of the part.

ARX External Head

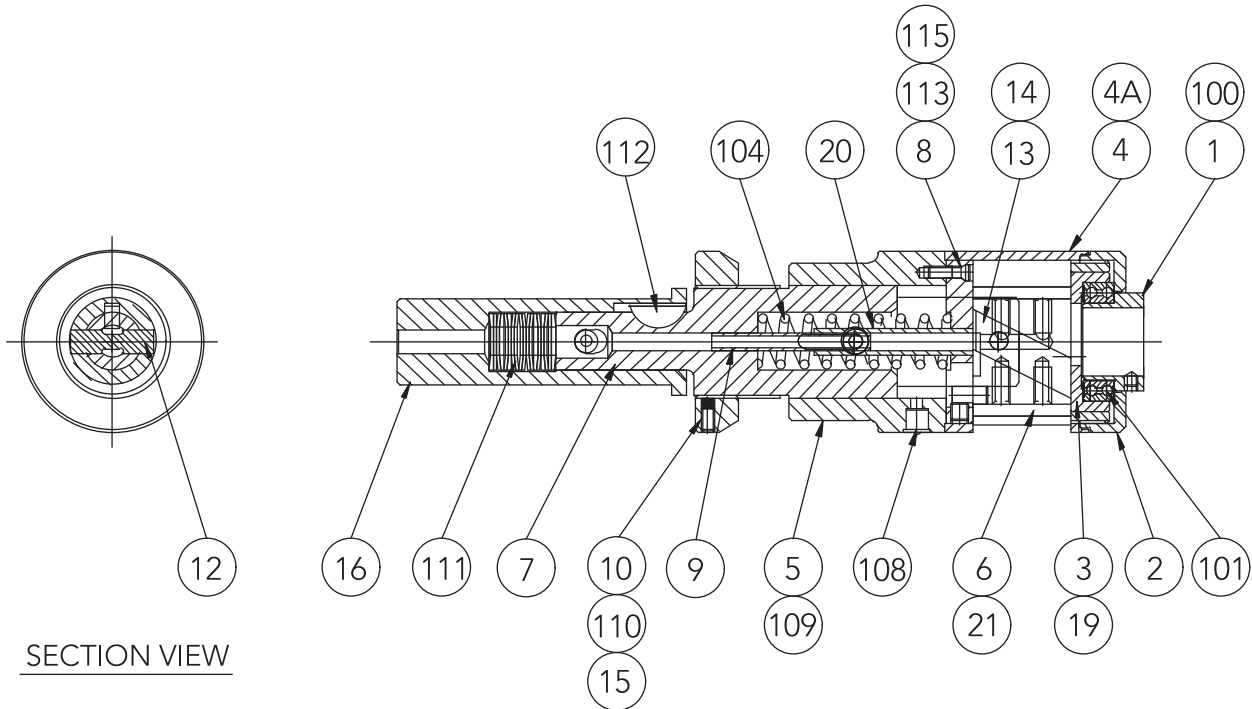

1 Master Pilot	8 Spring Plate	19 Back Plate Dowel	110 Micrometer Screw
2 Front Nut	9 Coolant Pipe	20 Spring Plate Pipe	111 Disc Springs
3 Back Plate	10 Micrometer Nut	21 Centralising Pin	112 Key
4 Standard Chip Guard	12 Over-rider Dowel	100 Set Screw	113 Torx Screw
4A Two Slot Chip Guard	13 Slipper	101 Double Angular Contact Bearing	115 Centralizing Screw
5 Front Body	14 Slipper Pin	104 Spring	
6 Toolslide	15 Copper Pad	108 Oiler	
7 Rear Body	16 Shank	109 Retaining Screw	

Pilots

Pilots are required to locate and stabilize the recessing head in the component bore. All pilots are manufactured to suit the application. Although the basic design and dimensions are standardized as shown on page 18, the locating diameter of the pilot is designed specifically for your component. Part pilots are retained in the master pilot by three retaining screws.

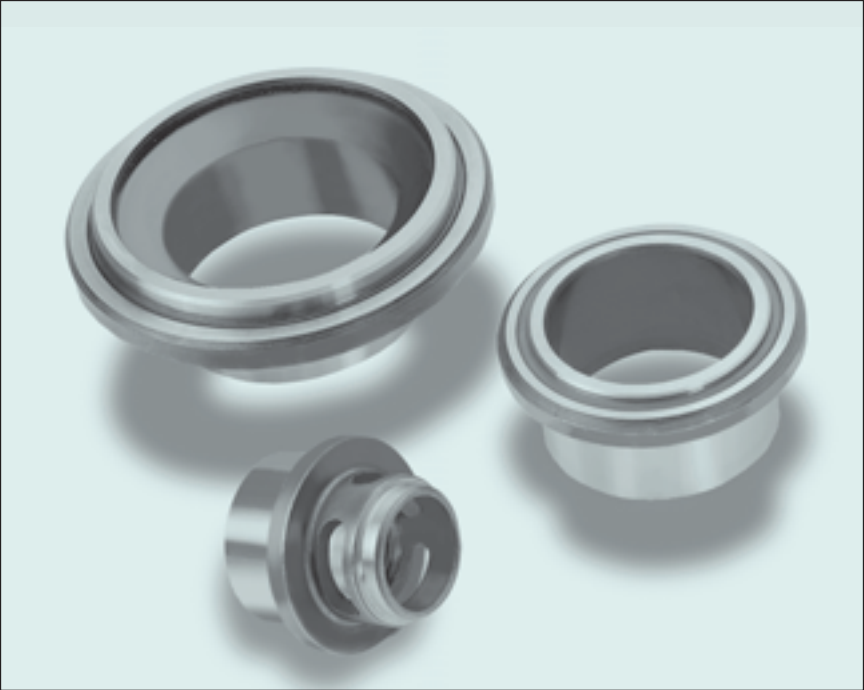

Specifications

PILOTS

AR Series

AUTOMATIC RECESSING

MASTER PILOT

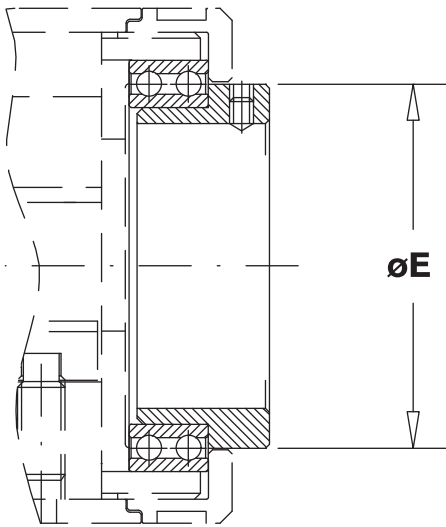

PART PILOT

3-DRILL DIMPLES
 $\phi G \times H^\circ$ INCL.
 EQUI-SPACED AS SHOWN

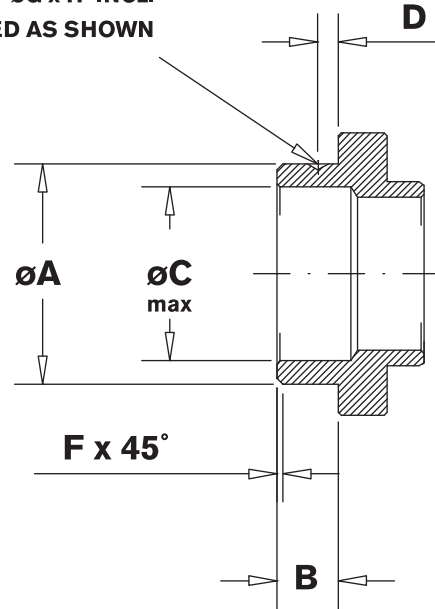

Note: If machine lacks internal coolant capability, part pilot must be designed with coolant windows

INCH [METRIC]

HEAD PILOTS	(ϕA) -.0003 [-0.008]	(B)	(ϕC) MAX	(D) -.005 [-0.13]	(ϕE) -.005 [-0.13]	(F)	(G)	(H)
ARSP-1	.5904 [14.995]	.394 [10.00]	.472 [12.00]	.098 [2.50]	.909 [23.10]	.394 [1.00]	.138 [3.50]	120°
ARSP-2	1.0896 [27.675]	.551 [14.00]	.969 [24.60]	.098 [2.50]	1.409 [35.80]	.394 [1.00]	.138 [3.50]	120°
AR10 ARX10	.5904 [14.995]	.500 [12.70]	.472 [12.00]	.100 [2.55]	.844 [21.45]	.394 [1.00]	.138 [3.50]	120°
AR16 ARX16	1.415 [35.95]	.551 [14.00]	1.295 [32.90]	.130 [3.30]	1.811 [46.00]	.394 [1.00]	.138 [3.50]	120°
AR20 ARX20	1.772 [44.99]	.748 [19.00]	1.63 [41.4]	.148 [3.75]	2.299 [58.40]	.394 [1.00]	.177 [4.50]	120°

ALL UNSPECIFIED DIMENSIONAL TOLERANCES ARE ± 0.005 [0.13]

Pilots on I.D. and stops on face of component.

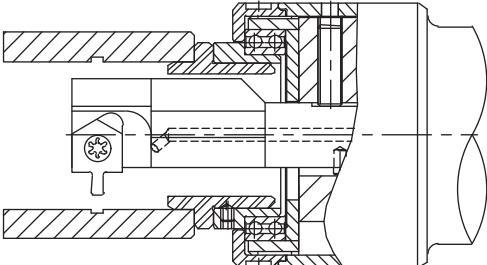

Pilots on O.D. and stops on face of component.

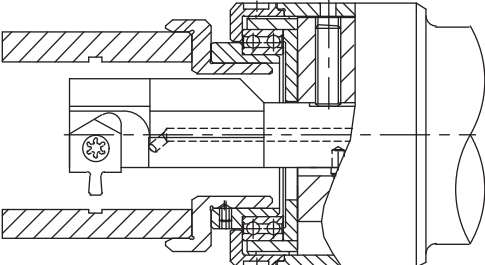

Pilots and stops on fixture plate.

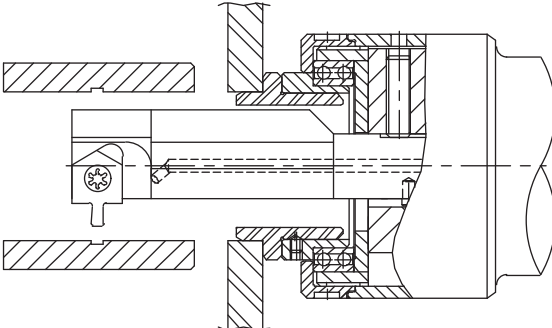

Pilots on fixture plate and stops on face of

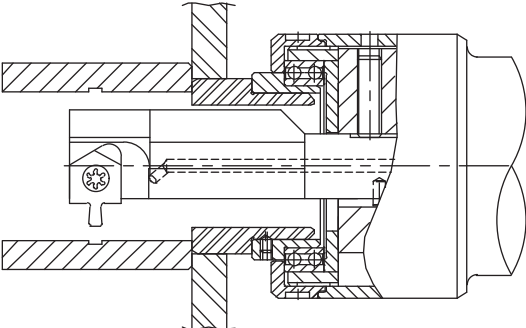

Toolholders, Cutters, Inserts

AR Series
AUTOMATIC RECESSING

Toolholders are designed to suit the application. The basic design of the toolholder is standardized (see page 21), but the diameter and length of the holder is designed to suit your component.

Toolholders with replaceable inserts are used where application parameters permit. As a general rule, toolholders for holes 9/16 inch (approx. 14.5mm) and larger utilize replaceable inserts. Cutters for smaller diameters are usually of brazed-carbide or high-speed steel construction.

Our improved toolholder design allows fast and easy incremental adjustment of axial groove location without removing the toolholder from the head.

Many inserts can be manufactured from standard blanks (see bottom of page 21.) Toolholders and inserts can be designed for back-chamfers, thread reliefs, multiple grooves, and special groove geometries; submit a part print and request a quotation. Toolholders can be designed with an internal coolant port where required (see example below).

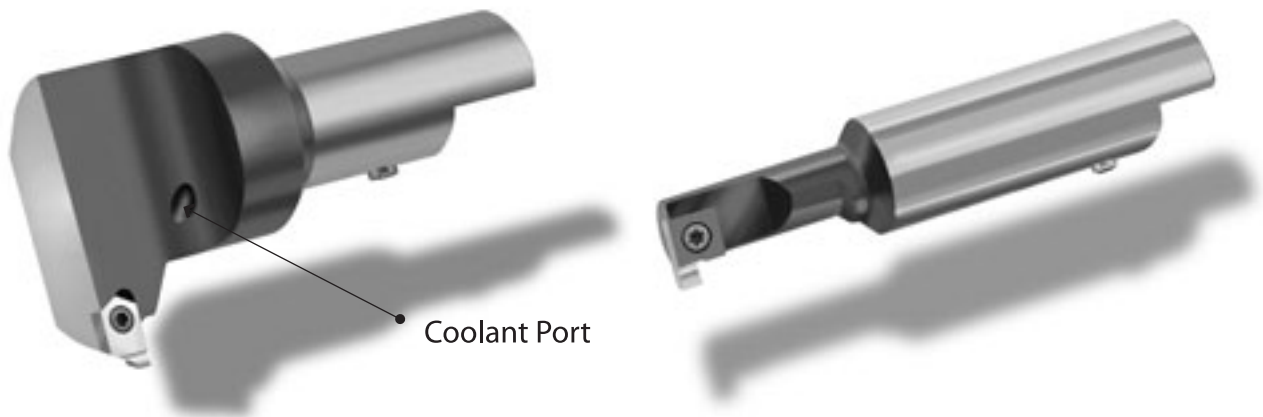

Our improved toolholder design allows fast and easy incremental adjustment of axial groove location without removing the toolholder from the head.

(See set-up and operation guide on page 22 for more information)

Specifications

TOOLHOLDER

AR Series

AUTOMATIC RECESSING

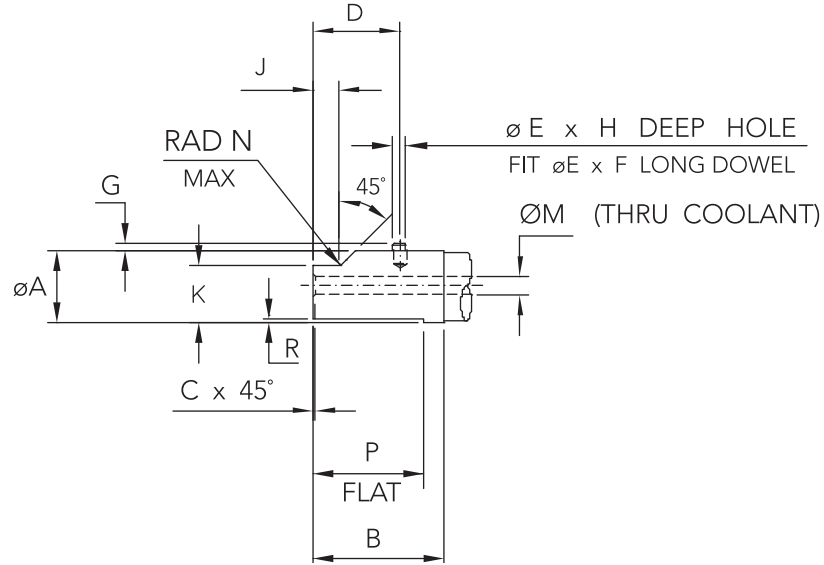

METRIC [INCH]

HEAD TYPE	(A)	(B)	(C)	(D)	(E)	(F)	(G) h11	(H)	(J)	(K)	ø(M)	(N) max	(P)	(R)
ARSP-1	10.00 [0.394]	12.70 [0.500]	0.50 [0.020]	9.00 [0.354]	1.50 [0.059]	3.00 [0.118]	0.70 [0.028]	2.30 [0.091]	3.35 [0.132]	8.00 [0.315]	3.00 [0.118]	0.50 [0.020]	9.50 [0.374]	0.70 [0.028]
ARSP-2	12.00 [0.472]	17.25 [0.679]	0.50 [0.020]	12.50 [0.492]	3.00 [0.118]	5.00 [0.197]	1.60 [0.063]	3.40 [0.134]	5.75 [0.226]	9.50 [0.374]	3.00 [0.118]	0.50 [0.020]	15.50 [0.610]	0.80 [0.031]
AR10	10.00 [0.394]	20.80 [0.819]	0.50 [0.020]	15.25 [0.600]	1.50 [0.059]	3.00 [0.118]	0.80 [0.031]	2.20 [0.087]	6.70 [0.264]	7.75 [0.305]	3.00 [0.118]	0.50 [0.020]	19.00 [0.748]	0.70 [0.028]
AR16	16.00 [0.630]	29.50 [1.161]	0.50 [0.020]	19.50 [0.768]	3.00 [0.118]	5.00 [0.197]	1.60 [0.063]	3.40 [0.134]	6.10 [0.240]	12.50 [0.492]	4.00 [0.157]	0.50 [0.020]	26.50 [1.043]	0.80 [0.031]
AR20	20.00 [0.787]	36.30 [1.429]	0.50 [0.020]	25.40 [1.000]	5.00 [0.197]	6.00 [0.236]	1.75 [0.069]	4.25 [0.167]	10.00 [0.394]	15.50 [0.610]	5.00 [0.197]	0.50 [0.020]	33.30 [1.311]	1.00 [0.039]

AR Series Replaceable Inserts



Standard insert blanks



Replaceable carbide inserts are used where applications permit. Special or intricate geometries are available.

There are four basic steps to the set-up of **AR** Series Automatic Recessing heads. (Set-up procedures differ somewhat for internal and external heads.)

1 Install pilot

For all head types, the pilot must be installed in the head.

The pilot will fit either directly into the sealed bearing or into a master pilot for quick and easy tool changes.

2 Install cutter/toolholder

The cutter normally comes in three different styles:

- High-speed steel cutter
- Tungsten carbide brazed-tip cutters
- Replaceable-insert toolholders

For **internal recessing heads**, install the cutter in the head with the cutting edge pointing in the direction of cut (i.e., in the direction of toolslide movement). The cutter is clamped and fixed in position by two set screws in the head. The cutter must be positioned radially in the head so that the cutting edge will be on center as the tool moves out to cut. This is facilitated by the use of a key in the cutter shank, which automatically aligns the cutting edge on center.

For **external recessing heads**, install the toolblock onto the toolslide and secure in place with two caphead screws. An adjustable cartridge is fitted to the toolblock and held in place by a buttonhead screw. An inexpensive, replaceable insert is fitted to this cartridge and secured in place by an insert screw. The cutting edge of the insert is automatically aligned on center as the toolblock is secured to the head.



3 Set cutter projection from pilot

For all head types, the projection of the cutter from the pilot must be set properly in order to achieve accurate groove location.

For **internal recessing heads**, groove location is controlled by the tool adjustment set screw, which is located in the toolslide. The tool adjustment screw is accessed through a hole in the chip guard on the front shell. Insert the toolholder until it bottoms out in the toolslide. Tighten tool adjustment screw and move cutter out until the set dimension (between cutter and pilot) is achieved. Then lock the cutter in place by tightening the locking set screws.

For **external recessing heads**, groove location is controlled by a set screw in the end of the adjustable cartridge that is mounted on the toolblock. Once the groove location is set, lock the cartridge in place with the buttonhead locking screw.

(continued)

4 Depth of cut/tool travel

For all head types, depth of cut is controlled by a micrometer nut that allows the head to pre-set off the machine. The standard tool feed ratio for all heads is 2:1 (i.e., the ratio of spindle to radial cutter movement).

Refer to the drawing supplied with the tool for the set-up dimension. If the drawing is unavailable, follow this procedure: Add the depth of cut (the distance from the I.D. of the bore to the bottom of the groove) to the clearance between the cutter and the I.D. of the bore. Multiply this figure by the feed ratio (i.e., multiply by 2 for standard feed ratio) in order to arrive at the distance to set the micrometer nut from the front body. This distance should be set using gauge blocks or by fine-tuning the micrometer nut position manually to achieve the desired groove depth.

HEX WRENCHES REQUIRED FOR ADJUSTING AR HEADS

HEAD TYPE	MICROMETER NUT SCREW	INSERT TOOL HOLDER (LENGTH ADJ.)	MASTER PILOT
AR10	1.5mm	2.0mm	1.5mm
AR16	3.0mm	3.0mm	1.5mm
AR20	4.0mm	4.0mm	2.0mm
ARSP-1	1.5mm	1.5mm	1.5mm
ARSP-2	2.5mm	2.5mm	1.5mm

Approximate adjustment gap for all internal recessing heads, when tool is in set position.

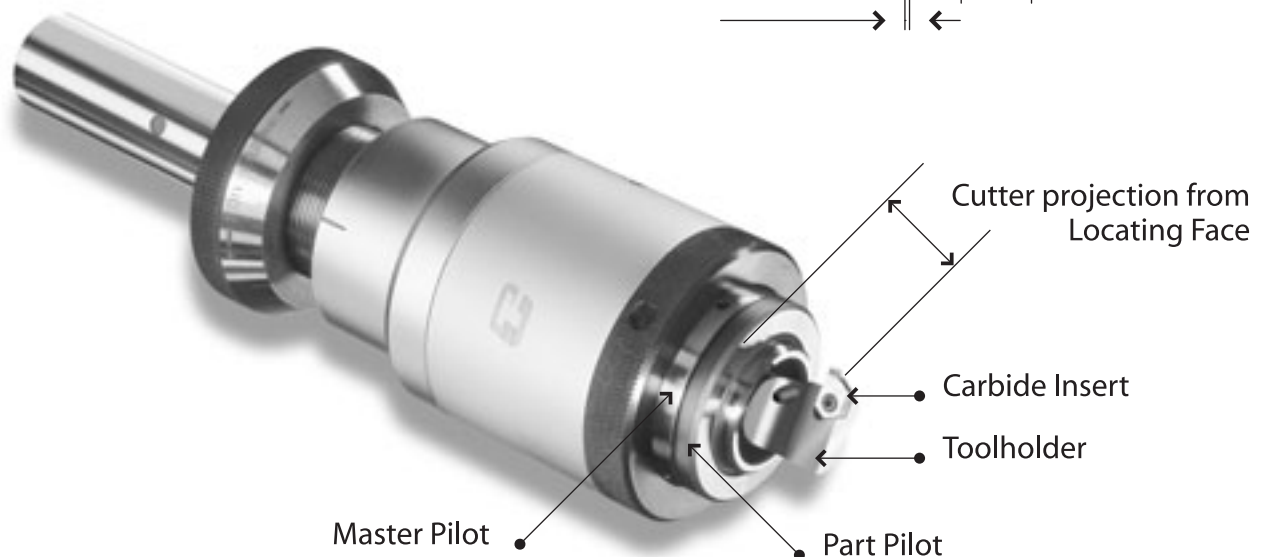
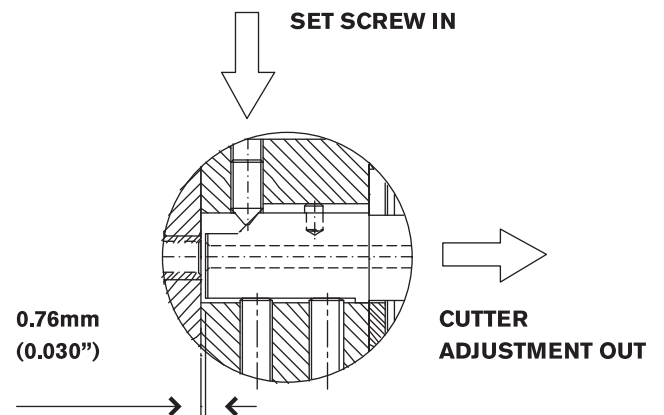

Speeds & Feeds

Please refer to the charts below for **speed and feed recommendations** for specific material types. The charts are intended as a guide or starting point; the actual speed and feed used will depend on a number of factors, including type of machine, condition of machine spindle, rigidity of fixturing, type of coolant used or dry cutting, tool length, cutter geometry, interrupted cut, etc.

INCH

MATERIAL	CUTTING SPEED (FT/MIN)		FEED RATE (INCHES/REV)		TOP RAKE (DEGREES)	
	HSS	Carbide	HSS	Carbide	HSS	Carbide
Aluminum	200–300	400–700	.002–.005	.002–.005	10–15	8–12
Brass	100–200	200–525	.002–.005	.002–.005	0–3	0–3
Bronze	50–130	100–400	.002–.005	.002–.005	3–5	3–5
Cast Iron	50–90	100–180	.002–.004	.002–.005	0–3	0–3
Copper	100–200	200–400	.002–.004	.002–.005	10–15	8–12
Magnesium	200–300	400–700	.004–.006	.004–.006	10–15	8–12
Malleable Cast Iron	50–90	100–200	.002–.004	.003–.005	0–3	0–3
Resin (Plastic)	70–135	160–400	.004–.006	.004–.006	10–15	8–12
Free Cutting Steel	70–100	100–230	.002–.004	.003–.005	5–10	4–8
Annealed Steel	50–70	100–200	.002–.004	.003–.005	5–8	3–6
Wrought Steel	35–70	85–220	.002–.003	.003–.004	5–8	3–6
Alloy Steel	35–70	85–220	.002–.003	.003–.004	4–6	3–6
Tool Steel	35–50	85–150	.001–.002	.002–.003	4–6	3–6
Monel & Stainless	85–135	150–250	.001–.003	.002–.004	10–20	8–12

METRIC

MATERIAL	CUTTING SPEED (M/MIN)		FEED RATE (MM/REV)		TOP RAKE (DEGREES)	
	HSS	Carbide	HSS	Carbide	HSS	Carbide
Aluminum	60–90	120–210	0,05–0,13	0,05–0,13	10–15	8–12
Brass	30–60	60–160	0,05–0,13	0,05–0,13	0–3	0–3
Bronze	15–40	30–120	0,05–0,13	0,05–0,13	3–5	3–5
Cast Iron	15–25	30–55	0,05–0,10	0,05–0,13	0–3	0–3
Copper	30–60	60–120	0,05–0,10	0,05–0,13	10–15	8–12
Magnesium	60–90	120–210	0,10–0,15	0,10–0,15	10–15	8–12
Malleable Cast Iron	15–25	30–60	0,05–0,10	0,08–0,13	0–3	0–3
Resin (Plastic)	20–40	50–120	0,10–0,15	0,10–0,15	10–15	8–12
Free Cutting Steel	20–30	30–70	0,05–0,10	0,08–0,13	5–10	4–8
Annealed Steel	15–20	30–60	0,05–0,10	0,08–0,13	5–8	3–6
Wrought Steel	10–20	25–65	0,05–0,08	0,08–0,10	5–8	3–6
Alloy Steel	10–20	25–65	0,05–0,08	0,08–0,10	4–6	3–6
Tool Steel	10–15	25–45	0,03–0,05	0,05–0,08	4–6	3–6
Monel & Stainless	25–40	45–75	0,03–0,08	0,05–0,10	10–20	8–12

(continued)

Coolant

Regarding the use of **coolant**, follow normal machine shop procedures for the cutter material and the material to be machined.

Lubrication

1 We recommend a water resistant grease for use in these heads. **Kluber Altemp Q NB50** has been thoroughly tested and found to perform exceptionally well – it is the only grease we recommend. It should be applied to all moving parts and surfaces when the head is disassembled for cleaning and maintenance, or if the head will be stored for extended periods. Disassembly and cleaning should be done periodically.

2 To lubricate the heads during use, apply **Kluber Altemp Q NB50** grease through the external oilers or grease fittings on the head. This should be done on a weekly basis, or more frequently if necessary. Lubrication frequency can vary depending on the working environment, operational speed, coolant used, and number of cycles. **Remember, adequate lubrication is vital to long head life and trouble-free performance.**

3 A high-pressure hand pump lube gun is available from Cogsdill to make routine maintenance easy. (Ref. Part No. **CN-D24**)

Other Non-Stocked and Special Recessing Solutions

AR Series
AUTOMATIC RECESSING



AR-S

A variation of the AR head for use on CNC machining or turning centers. No micrometer stop for depth control. Depth of cut is controlled by “Z” axis; axial adjustment is controlled by tool adjustment. Through-tool coolant.

ARX-S

A variation of the ARX head for use on CNC machining or turning centers. No micrometer stop for depth control. Depth of cut is controlled by “Z” axis; axial adjustment is controlled by tool adjustment.



ARJ

Designed to run in a rotating bushing mounted in a jig plate. Exceptional rigidity, especially at high cutting speeds. Micrometer stop controls depth of cut. Through-tool coolant.

ARXJ

For machining grooves or forms in larger bores or for other special applications. Rigid support in heavy cuts. Micrometer stop controls depth of cut. Axial location controlled by adjustable thrust housing. Through-tool coolant.



Inquire about these and other non-stocked and special Recessing tool designs. Submit a completed Application Data Sheet (see pages 62-63) and request a quotation, or contact our Customer Service Department for more information.

AR10 Internal Recessing Head

performing an I.D. grooving operation; pilots in part

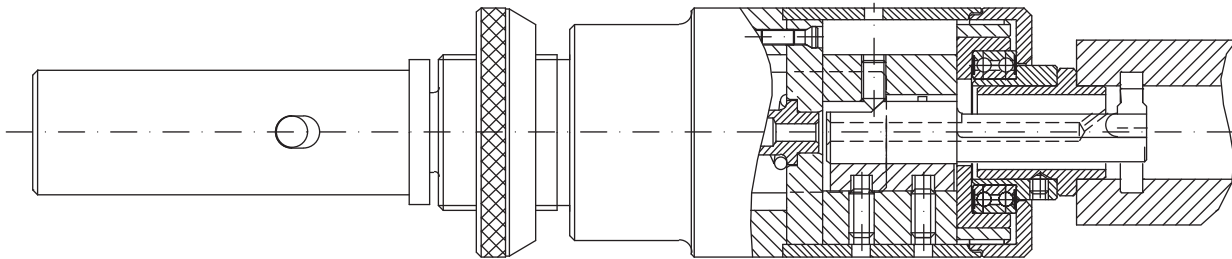

ARSP1 Internal Recessing Head

machining an I.D. groove with a radius on a banjo fitting; pilots in part

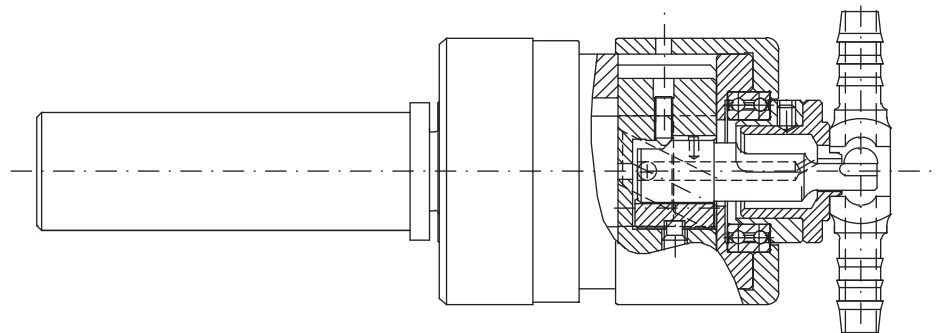

AR20 Internal Recessing Head

machining a back-spotface with an I.D. chamfer; pilots in part

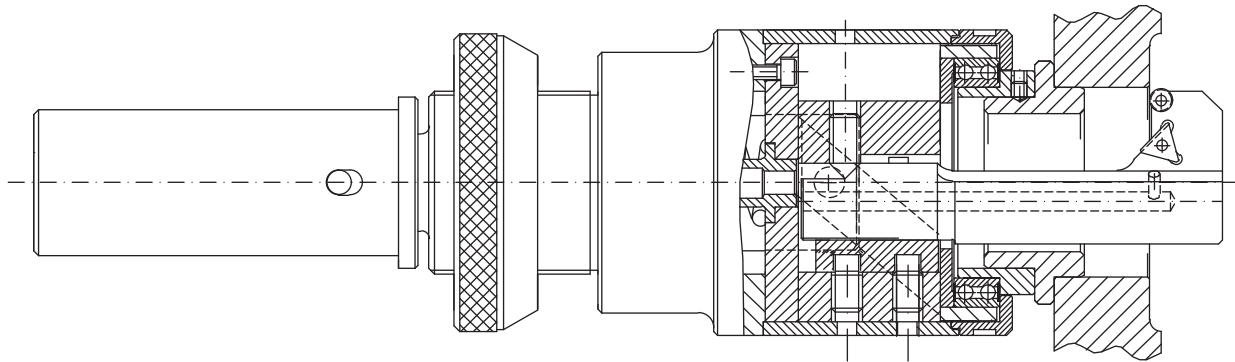

AR16 Internal Recessing Head

performing an I.D. grooving operation; pilots in fixture plate

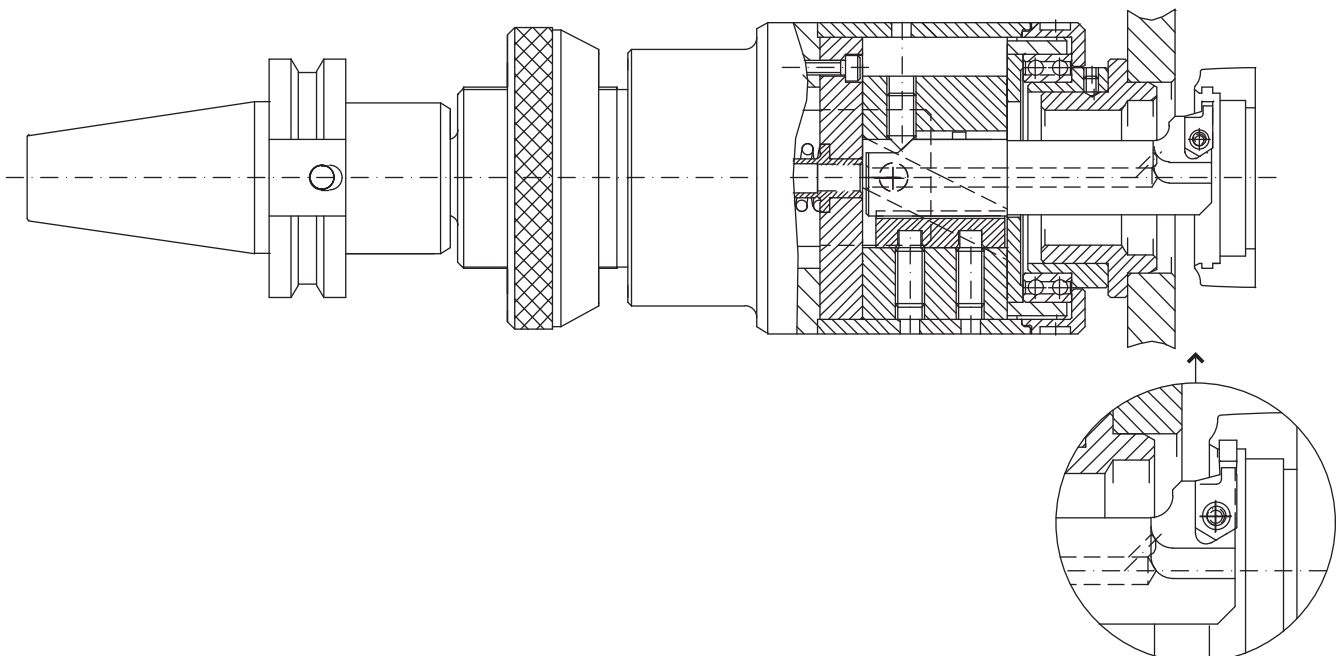

ARX10 External Recessing Head

performing an O.D. grooving operation; pilots on part O.D. and includes balance weight

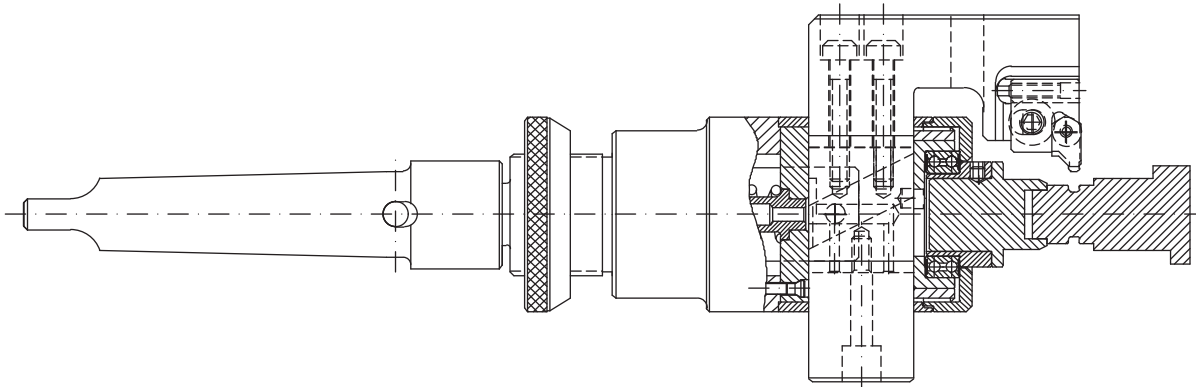

ARX16 External Recessing Head

machining a face and a double groove on an O.D.; pilots on part O.D.

